

**STATE**

**OF**

**TENNESSEE**

March 1, 2006

**SPECIAL PROVISION**

**REGARDING**

**DOWEL BAR RETROFITTING**

**DESCRIPTION**

The work consists of installing epoxy coated 1-1/2 inch diameter by 18 inch long plain round dowel bars into existing concrete pavement. The existing Portland Cement Concrete pavement shall be slotted and the dowel bars shall be retrofit across pavement cracks and/or joints.

**MATERIALS** (See Standard Specifications for other details)

Dowel bars, including the ends, shall be epoxy coated. The dowel bars shall also be further coated prior to installation with a bond breaking compound. The bond breaking coating shall be one of the approved products appearing on the Department's Qualified Products List.

The dowel bars shall have tight fitting end caps made of nonmetallic material that allows for 1/4 inch bar movement at each end of the bar. The Contractor shall submit an end cap sample to the Engineer for approval prior to installation.

Chair devices for supporting and holding the dowel bar in place during placement of the patching material shall be completely epoxy coated and made of nonmetallic material. The Contractor shall submit a chair sample to the Engineer for approval prior to installation.

The foam core board filler material shall be 1/4 inch thick, constructed of closed cell foam and faced with poster board material on each side. The foam core board is to be used when existing transverse joints are being retrofitted.

The caulk for sealing the existing crack/joint at the bottom and sides of the slot shall be a commercial grade of silicone caulk containing a minimum of 50 percent silicone.

The Portland cement concrete pavement that is removed to install the dowel bars shall be replaced with one of the following approved patching products: Patchroc 1060, Five Star Highway Patch, Burke 928 Fast Patch, or an approved equal. The use of Set 45 will not be allowed.

The patching material may be extended with aggregate meeting the manufacturer's recommendations. The Contractor shall provide a concrete mix design, including all additives, to meet a minimum compressive strength of 4,000 psi in 6 hours.

The Contractor shall verify the results of the mix design prior to beginning work. If the mix design is not satisfactory, the Contractor shall provide the Department with a mix design that meets the requirement

prior to the beginning of work.

**CONSTRUCTION REQUIREMENTS**

The Contractor shall install the dowel bars in the existing Portland cement concrete pavement as shown in the plans and according to the following requirements:

1. Diamond saw cut the pavement to place the center of the dowel bar at mid-depth in the pavement. Multiple saw cuts parallel to the center line may be required to properly remove the waste material from the slot. The saw cuts for the six slots at each transverse crack/joint shall be made such that the dowel bars are placed within the following tolerances:

Centerline of individual dowel bars shall be parallel to the top of pavement, parallel to the other dowel bars, and parallel to the roadway centerline within + or - 1/4 inch in 18 inches.

2. Any jackhammers used to break loose the concrete shall not be larger than the 30 pound class. If the pavement is damaged by the 30 pound jackhammer, the engineer will require the Contractor to use a 15 pound hammer.
3. All surfaces exposed and cracks in the slot shall be sand blasted and cleaned prior to bar installation.
4. The crack/joint on the bottom and the sides of the slot shall be filled with silicone caulk.
5. The dowel bars shall be lightly coated with the bond breaking compound prior to placement. The bar chairs shall provide a minimum of 1/2 inch clearance between the bottom of the dowel bar and the bottom of the slot. The dowel bar shall be placed to the depth shown on the plans, parallel to centerline and the top of the roadway surface, and at the middle of the slot, all within the specified tolerances. The chairs shall hold the dowel bar securely in place during placement of the patching mix.

Longitudinal dowel bar placement for skewed joints or cracks shall be within + or - 2 inches. Longitudinal dowel bar placement for perpendicular joints shall be within + or - 1 inch.

6. The 1/4 inch thick foam core board shall be placed at the middle of the dowel bar to maintain a transverse contraction joint. The existing joint sealant may need to be cut or removed to accommodate the 1/4 inch thick foam core board with 1/2 inch by 1 inch tabs. The tabs are required to stabilize the foam core board during patching material placement. The foam core board shall fit tightly around the dowel bar and to the bottom and edges of the slot. The top of the foam core board shall be flush with the top surface of the concrete pavement.

The Contractor may need to increase the width of the foam core board for pavements with skewed joints. The skew angle may vary for different pavement sections.

The Contractor shall caulk the transverse joint crack at the bottom and the sides of the slot on both sides of the 1/4 inch thick foam core board. The foam core board shall be capable of remaining in a vertical position and tight to all edges during the placement of the patching material.

If for any reason the foam core board shifts during the placement of the patching material, the work shall be rejected and replaced at the Contractor's expense.

7. The Contractor shall thoroughly moisten all surfaces on the sawed slot immediately prior to filling with patching compound. Care shall be taken to prevent standing water in the slot. All excess water shall be removed with compressed air.

The Contractor shall fill the slot (with the installed dowel bar, chairs, foam core board where used, and silicone in place) with an approved patching material. The patching material shall be vibrated with a small hand held vibrator capable of thoroughly consolidating the patching material into the slot and around the dowel bar. The top surface of the filled slot shall be trowel finished and cured immediately after each group of three dowels are installed. The curing compound shall meet the requirements of the Standard Specifications.

The patching material shall be mixed with a hand mixer. The Engineer will test the patching material once every four hours of production. The patching material shall have a minimum compressive strength of 4,000 psi in 6 hours. Department compression testing may be performed up to 24 hours after the cylinders are made. If the compressive strengths are not being met, production shall cease and the Contractor shall resubmit a concrete mix design correcting the strength problems.

8. The transverse contraction joints shall be sawed and sealed as required in the Standard Drawings within 24 hours after placement of the patching material.
9. Any damage to the pavement due to the Contractor's operation shall be repaired or replaced at the expense of the Contractor.

#### MEASUREMENT

Dowel bar retrofit will be measured by each dowel bar installed and accepted.

#### PAYMENT

Dowel bar retrofit will be paid at the contract unit price bid per each dowel bar. Payment shall be full compensation for equipment, materials, labor, and all incidentals required.

SP503DB

### DOWEL BAR RETROFIT DETAILS

SP503DB

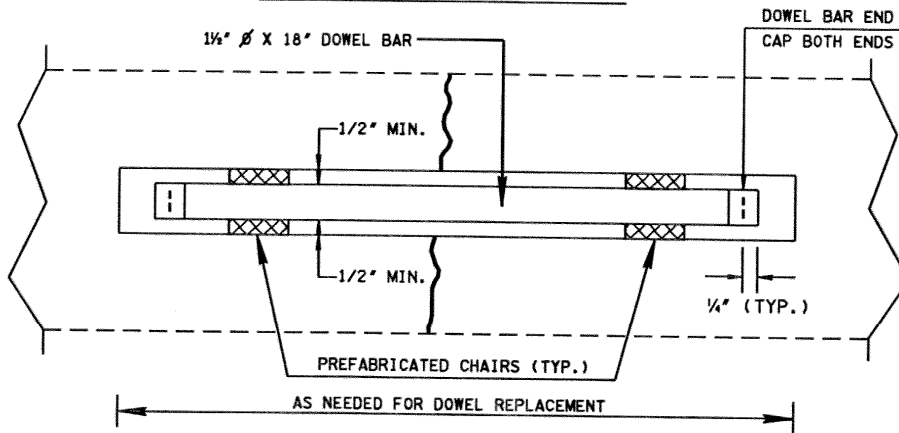

PLAN

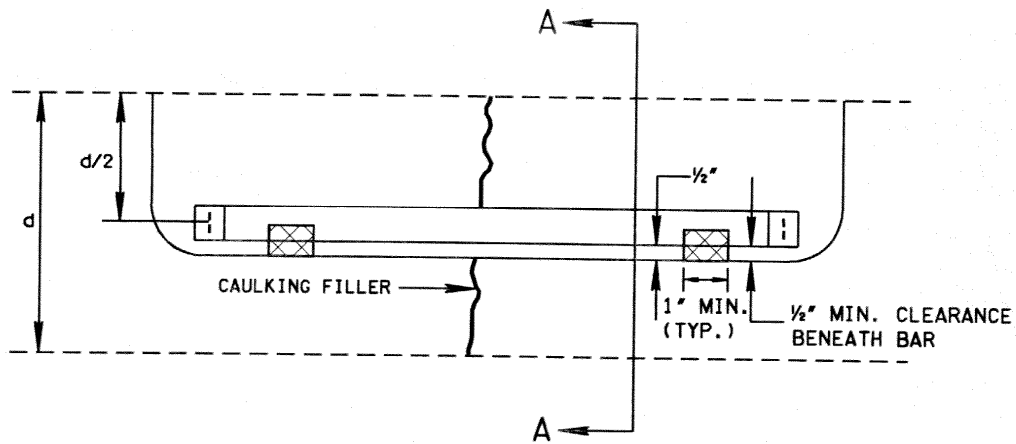

ELEVATION

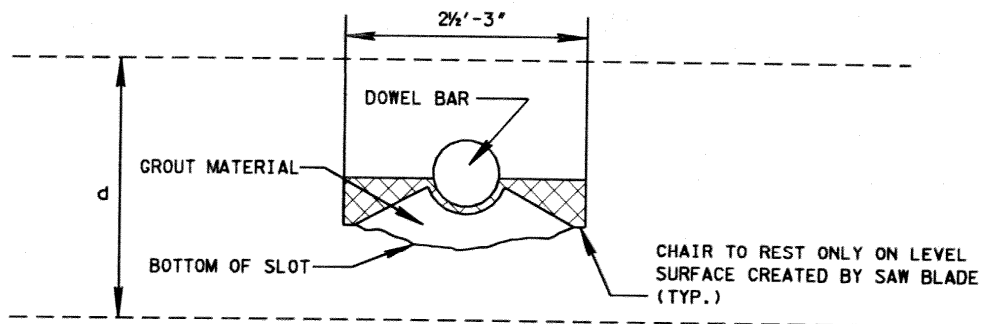

SECTION A-A

SP503DB

SP503DB

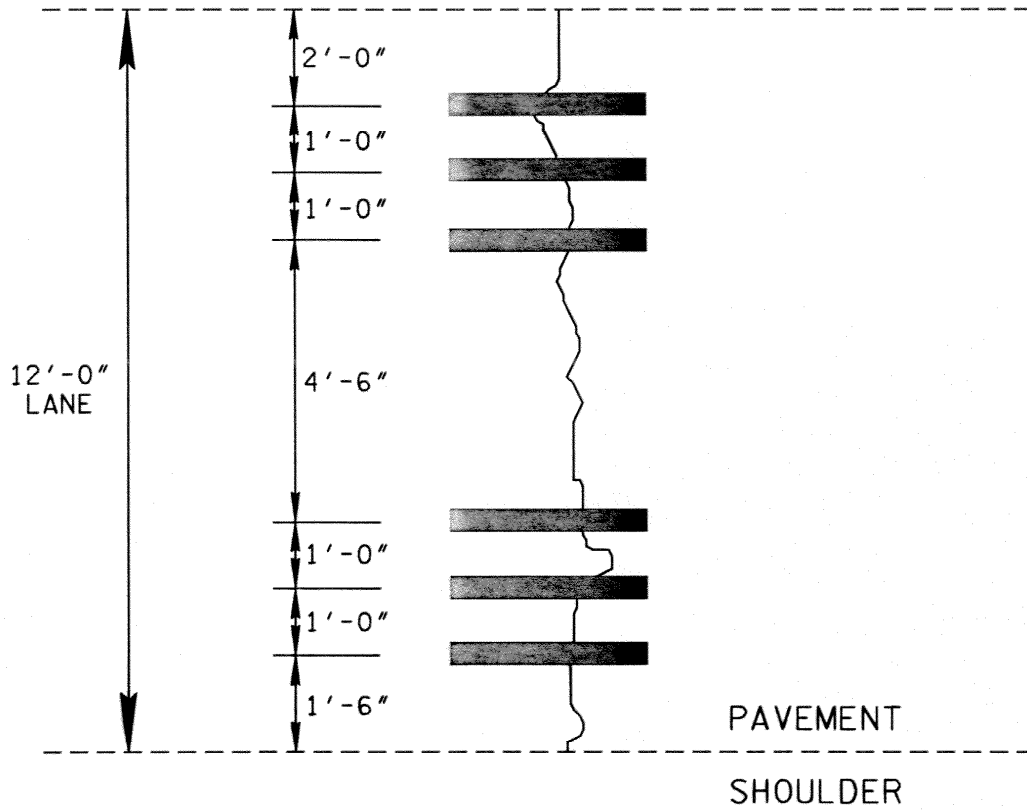

DOWEL BAR PLACEMENT